

Nombre: \_\_\_\_\_ Apellido: \_\_\_\_\_

Asignación: Para Hacer Ahora (9/21-9/25) (Fifth)

**Es el veintiuno de septiembre**

**Las metas: Our goals are to review question words and Central American countries & capitals.**

*Fill in the blanks with the correct question word. Remember to use PUNCTUATION!*

1. How? \_\_\_\_\_
2. When? \_\_\_\_\_
3. Which? \_\_\_\_\_
4. What? \_\_\_\_\_
5. Where? \_\_\_\_\_

**Es el veintidós de septiembre**

**Las metas: Our goals are to review question words and Central American countries & capitals.**

*Fill in the capital of each country given.*

1. México \_\_\_\_\_
2. Guatemala \_\_\_\_\_
3. El Salvador \_\_\_\_\_
4. Nicaragua \_\_\_\_\_
5. República Dominicana \_\_\_\_\_

**Es el veintitrés de septiembre**

**Las metas: Our goals are to demonstrate our knowledge of Question words & C. America, and to review clothing vocabulary.**

*Fill in the blanks with the correct question word. Remember to use PUNCTUATION!*

1. How much? \_\_\_\_\_
2. Who? \_\_\_\_\_
3. Why? \_\_\_\_\_
4. How? \_\_\_\_\_
5. Where? \_\_\_\_\_

Es el veinticuatro de septiembre

Las metas: Our goals are to practice/review clothing vocabulary and the seasons.

Write the Spanish word for each English word given. Include el, la, los or las.

1. coat \_\_\_\_\_ 3. blouse \_\_\_\_\_  
2. robe \_\_\_\_\_ 4. scarf \_\_\_\_\_

Es el veinticinco de septiembre

Las metas: Our goals are to practice/review clothing vocabulary and the seasons.

Write the Spanish word for each English word given. Include el, la, los or las.

1. socks \_\_\_\_\_ 3. vest \_\_\_\_\_  
2. shirt \_\_\_\_\_ 4. tie \_\_\_\_\_

**Al Fin**

Each day we will complete an "Al Fin" to wrap up class.

**LUNES:** Fill in the missing country for the capital given.

San José: \_\_\_\_\_

**MARTES:** Rate it! How ready are you for FK 4-Q. Words & Central America?

3-I'm READY!

2-I'm good once I study!

1-Not ready at all ☹️

**MIÉRCOLES:** Write down two clothing words from last year (IN SPANISH!)

\_\_\_\_\_

**JUEVES:** Write the appropriate season in which to wear the clothing item below.

\*\*\*\*Use **EL VERANO** or **EL INVIERNO**.

el traje de baño \_\_\_\_\_

**VIERNES:** Circle whether you would use Tú or Usted in each situation below.

1. Your best friend                      Tú                      Usted  
2. The school principal                      Tú                      Usted

Nombre: \_\_\_\_\_ Apellido: \_\_\_\_\_

Fecha: Es el \_\_\_\_\_ de \_\_\_\_\_

Asignación: Tarea: Countries & Capitals of Central America

**Fill in the spaces with the correct missing information!**

<b><u>El País</u></b>	<b><u>La Capital</u></b>
México	
	Guatemala
	San Salvador
Nicaragua	
	Tegucigalpa
Costa Rica	
	La Habana
Puerto Rico	
Panamá	
República Dominicana	

Write the English meaning of each Question Word below!

1. ¿Cuál? \_\_\_\_\_

2. ¿Cuánto? \_\_\_\_\_

3. ¿Dónde? \_\_\_\_\_

4. ¿Cómo? \_\_\_\_\_

5. ¿Cuándo? \_\_\_\_\_

6. ¿Adónde? \_\_\_\_\_

7. ¿Qué? \_\_\_\_\_

8. ¿Quién? \_\_\_\_\_

9. ¿De dónde es? \_\_\_\_\_

10. ¿Por qué? \_\_\_\_\_

Nombre: \_\_\_\_\_ Apellido: \_\_\_\_\_

Fecha: Es el \_\_\_\_\_ de \_\_\_\_\_

Asignación: Minuto Loco with Question Words & Central America

**Match each Question Word with its English meaning, and each country with its capital.**

- |                                |                  |
|--------------------------------|------------------|
| 1. ¿Cómo? _____                | A. Guatemala     |
| 2. México _____                | B. What?         |
| 3. ¿Cuándo? _____              | C. Managua       |
| 4. Guatemala _____             | D. When?         |
| 5. ¿Cuál? _____                | E. México D.F.   |
| 6. El Salvador _____           | F. How?          |
| 7. ¿Qué? _____                 | G. Tegucigalpa   |
| 8. Nicaragua _____             | H. San José      |
| 9. ¿Dónde? _____               | I. How much?     |
| 10. Honduras _____             | J. Which?        |
| 11. ¿Cuánto? _____             | K. San Salvador  |
| 12. Costa Rica _____           | L. Who?          |
| 13. ¿Quién? _____              | M. Santo Domingo |
| 14. Cuba _____                 | N. Panamá        |
| 15. ¿Por qué? _____            | O. San Juan      |
| 16. Panamá _____               | P. La Habana     |
| 17. Puerto Rico _____          | Q. Why?          |
| 18. República Dominicana _____ | R. Where?        |

Nombre: \_\_\_\_\_ Apellido: \_\_\_\_\_

La fecha: Es el \_\_\_\_\_ de \_\_\_\_\_

Asignación: Examencito: FK 4 – Question Words & Central America (A)

**A. Match each question word on the left with the correct English translation on the right. DO NOT DRAW LINES. Mark the correct letter of your choice on the line provided.**

- |                    |              |
|--------------------|--------------|
| 1. _____ ¿Dónde?   | A. What?     |
| 2. _____ ¿Qué?     | B. When?     |
| 3. _____ ¿Cuánto?  | C. Where?    |
| 4. _____ ¿Cómo?    | D. Why?      |
| 5. _____ ¿Cuál?    | E. How?      |
| 6. _____ ¿Por qué? | F. How many? |
| 7. _____ ¿Cuándo?  | G. Which     |
| 8. _____ ¿Quién?   | H. Who?      |

**B. Write the letter of each capital in front of the correct country. DO NOT DRAW LINES!!!**

- |                                |                  |
|--------------------------------|------------------|
| 1. _____ México                | A. San José      |
| 2. _____ Guatemala             | B. La Habana     |
| 3. _____ El Salvador           | C. Guatemala     |
| 4. _____ Nicaragua             | D. Tegucigalpa   |
| 5. _____ Honduras              | E. San Juan      |
| 6. _____ Costa Rica            | F. México, D.F.  |
| 7. _____ Panamá                | G. Managua       |
| 8. _____ Cuba                  | H. Panamá        |
| 9. _____ Puerto Rico           | I. Santo Domingo |
| 10. _____ República Dominicana | J. San Salvador  |

Nombre: \_\_\_\_\_ Apellido: \_\_\_\_\_

La fecha: Es el \_\_\_\_\_ de \_\_\_\_\_

Asignación: Examencito: FK 4 – Question Words & Central America (B)

**A. Match each question word on the left with the correct English translation on the right. DO NOT DRAW LINES. Mark the correct letter of your choice on the line provided.**

- |                   |              |
|-------------------|--------------|
| 1. _____ ¿Dónde?  | A. What?     |
| 2. _____ ¿Qué?    | B. Where?    |
| 3. _____ ¿Cuánto? | C. How?      |
| 4. _____ ¿Cómo?   | D. How many? |
- 

- |                    |           |
|--------------------|-----------|
| 5. _____ ¿Cuál?    | A. Why?   |
| 6. _____ ¿Por qué? | B. When?  |
| 7. _____ ¿Cuándo?  | C. Which? |
| 8. _____ ¿Quién?   | D. Who?   |

**B. Write the letter of each capital in front of the correct country. DO NOT DRAW LINES!!!**

- |                      |                 |
|----------------------|-----------------|
| 1. _____ México      | A. México, D.F. |
| 2. _____ Guatemala   | B. Managua      |
| 3. _____ El Salvador | C. Guatemala    |
| 4. _____ Nicaragua   | D. San Salvador |
| 5. _____ Honduras    | E. Tegucigalpa  |
- 

- |                                |                  |
|--------------------------------|------------------|
| 6. _____ Costa Rica            | F. San Juan      |
| 7. _____ Panamá                | G. La Habana     |
| 8. _____ Cuba                  | H. Panamá        |
| 9. _____ Puerto Rico           | I. Santo Domingo |
| 10. _____ República Dominicana | J. San José      |







# Clothes Closet



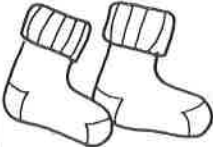

Me llamo \_\_\_\_\_.

Tengo \_\_\_\_\_ años.

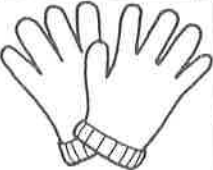
Refer to the Word Bank and write the Spanish word for each item of clothing pictured.

Word Bank		
vestido	cinturón	pantalones
sombrero	botas	zapatos
guantes	falda	chaqueta
calcetines		camisa
pantalones cortos		

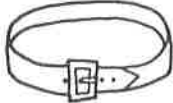
 shirt	
 shorts	
 socks	
 shoes	
 boots	
 gloves	

 pants	
 hat	
 skirt	
 belt	
 dress	
 jacket	





# Dressing Up

Me llamo \_\_\_\_\_ .

Tengo \_\_\_\_\_ años.

Write the Spanish word for each clue in the crossword puzzle.

### Across

- 1. shoes
- 4. socks
- 7. dress
- 8. gloves
- 9. hat
- 10. shirt

### Down

- 2. pants
- 3. skirt
- 4. jacket
- 5. belt
- 6. boots

### Word Bank

- |            |            |          |
|------------|------------|----------|
| cinturón   | botas      | camisa   |
| guantes    | calcetines | sombrero |
| chaqueta   | falda      | zapatos  |
| pantalones | vestido    |          |

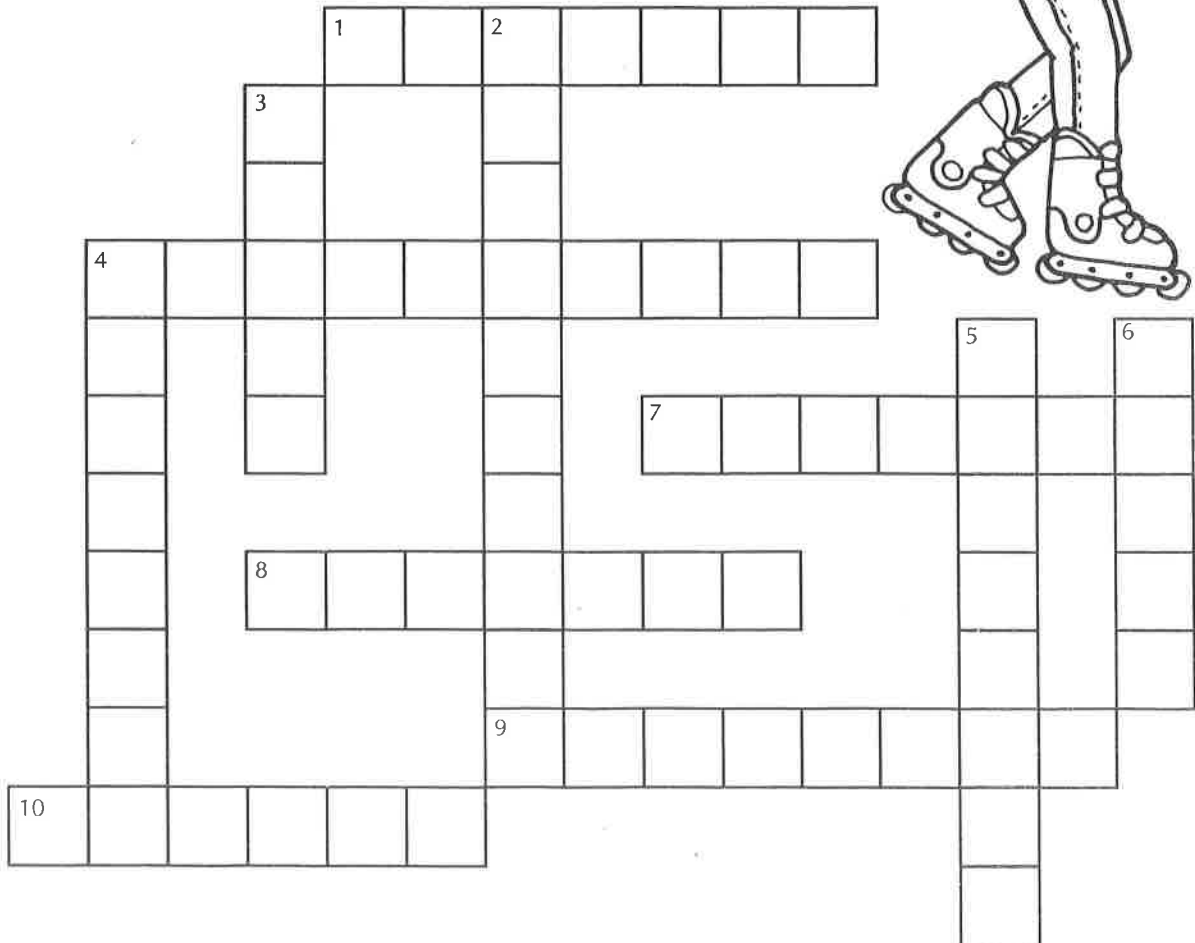
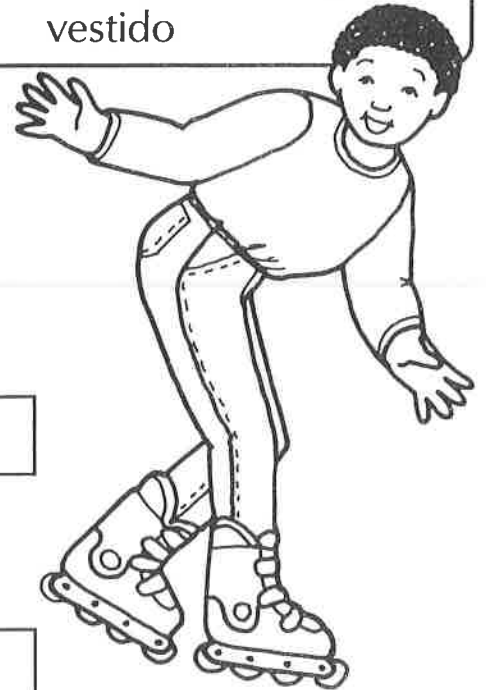

Nombre: \_\_\_\_\_ Apellido: \_\_\_\_\_

Es el \_\_\_\_\_ de \_\_\_\_\_

Directions: Classify the following words into the appropriate season

**Word Bank:**

El abrigo    La bufanda    Las guantes    Los pantalones    Las gafas de sol

Las botas    Las sandalias    El traje de baño    La chaqueta

Los pantalones cortos    La camiseta    El sombrero    La falda

El suéter de cuello alto    La sudadera    El suéter    Las chancletas

**El invierno**

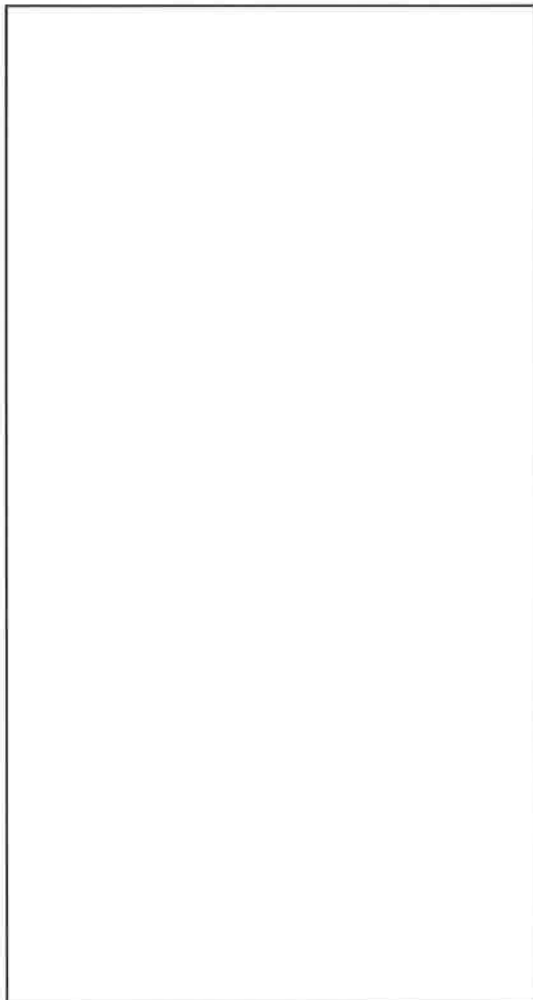

**El verano**

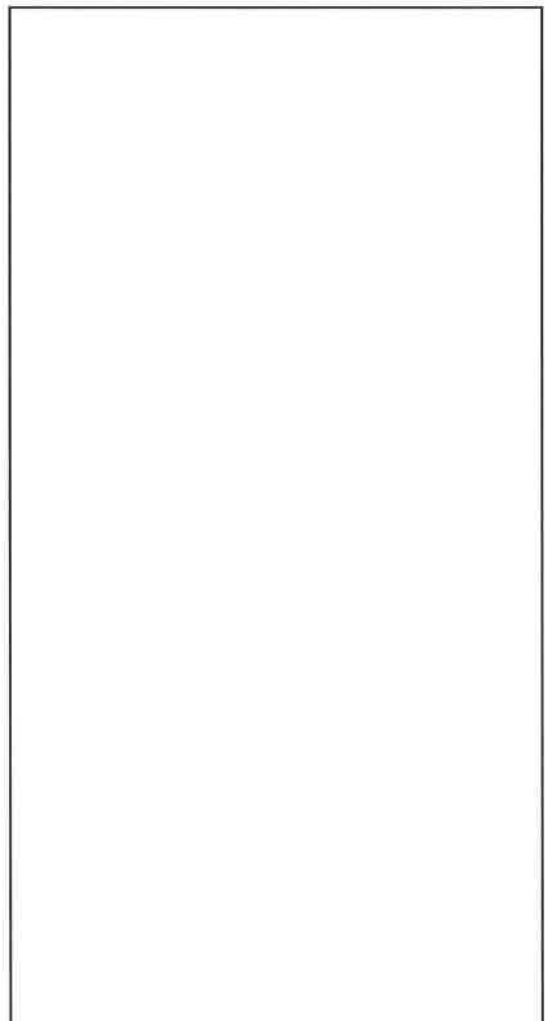

# Accessories

Name \_\_\_\_\_

Date \_\_\_\_\_

Teacher \_\_\_\_\_

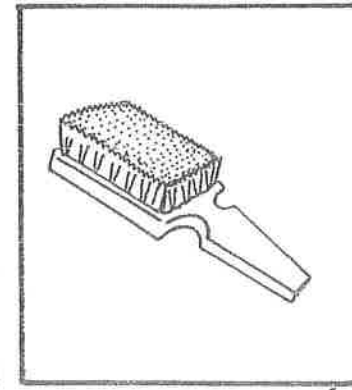
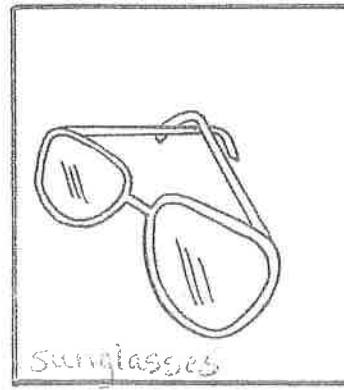
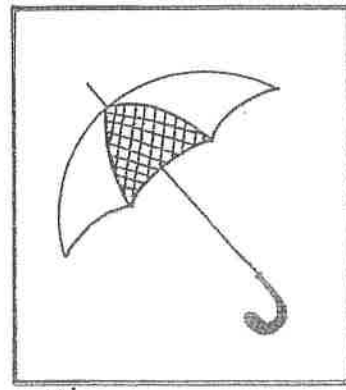
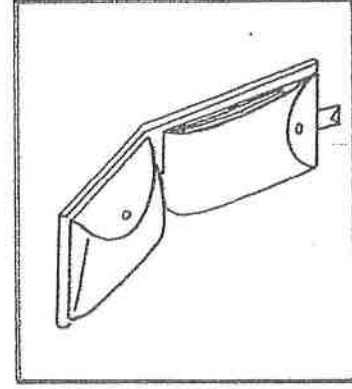
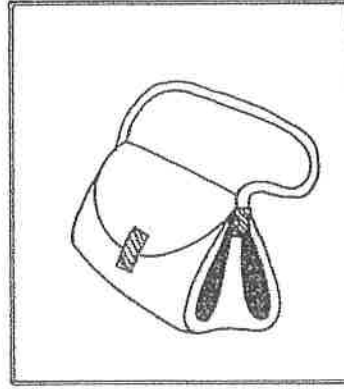
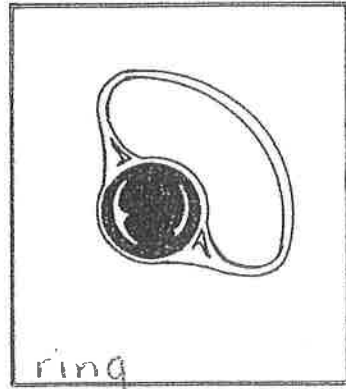
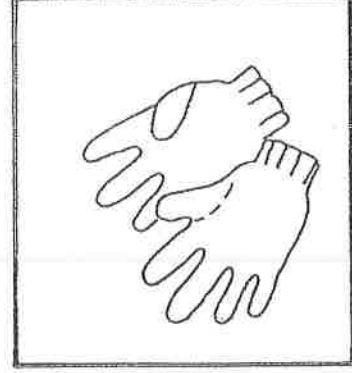
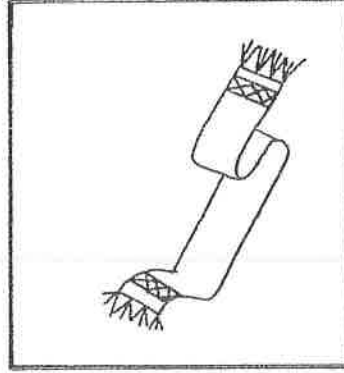
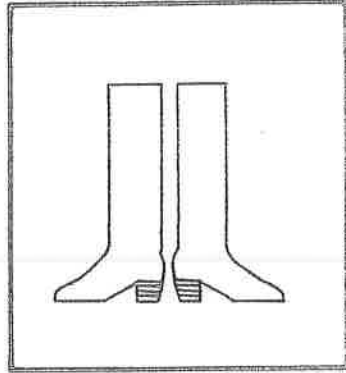
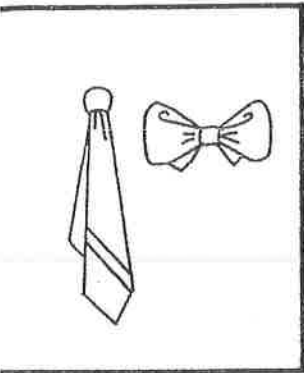
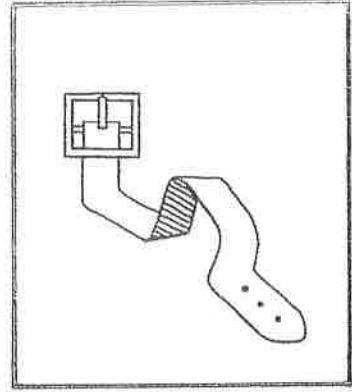
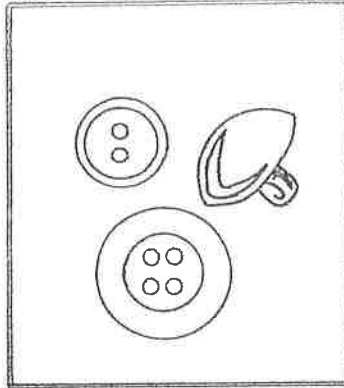
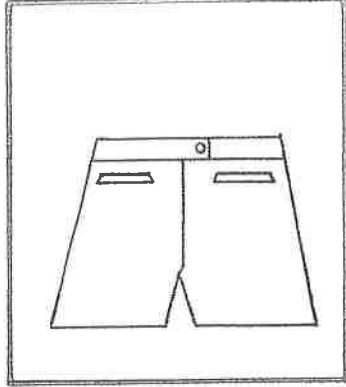
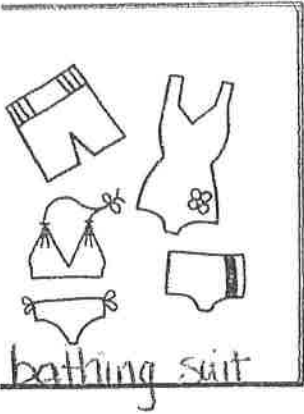

# 2. Clothing

Name \_\_\_\_\_

Date \_\_\_\_\_

Teacher \_\_\_\_\_

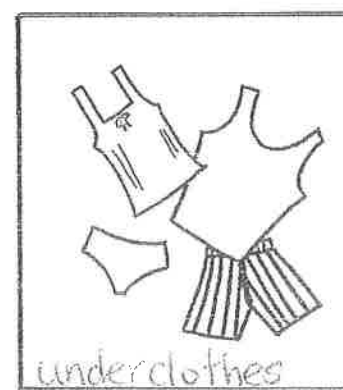
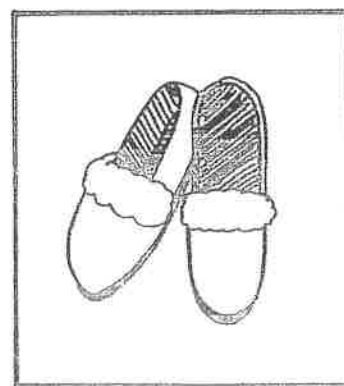
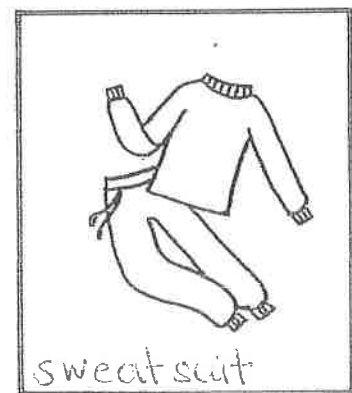
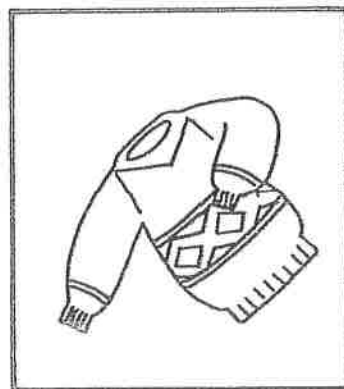
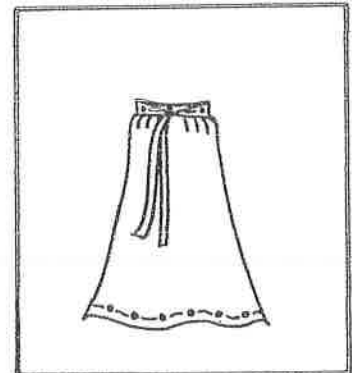
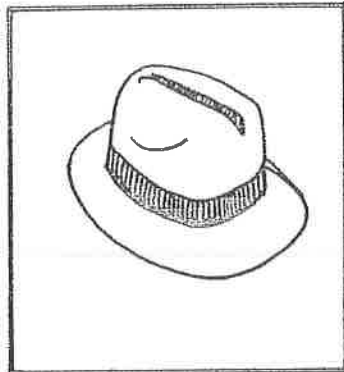
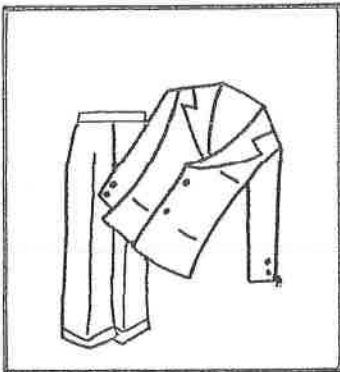
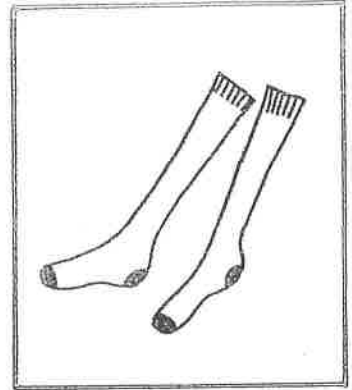
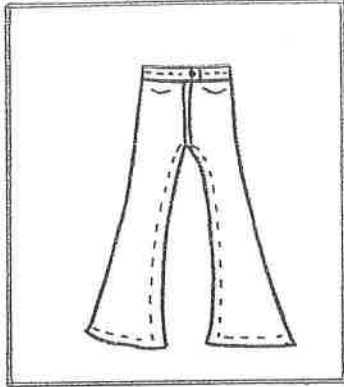
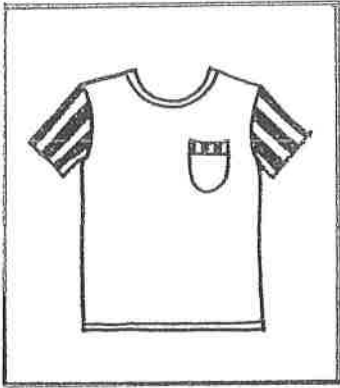

4/25